



Wheel bearings with single wheel rim - extremely robust and reliable

tailor-made

We design and manufacture your products according to your demands. Standards and regulatories just serve as construction base. Fine adjustments and modifications are executed correspondingly to your requirements.

Warmly welcome!

Wheel bearings are heavy-duty components which are subject to high loads.

Our high quality components are required, when maximum safety and reliability are needed.

High safety standards and permanent availability of the transport systems are major aspects for long-standing costumers who trust in BÖHMER quality.

BÖHMER-products are in permanent use by crane manufacturers, in smelting works, on transshipment stations, maritime freight handling agencies and many other crane operators.

What we can do for you:

Long-term experience and ongoing commitment in research and development enable us to offer customer and application-taylorred solutions.

Wheel bearings are designed according to standards, customer's drawings or construction proposals by our engineering department that have been authorised by you.

As technical base standards serve, costumers' drawings, technical data, load calculations or just simple sketches. The rest will be done by our experts.

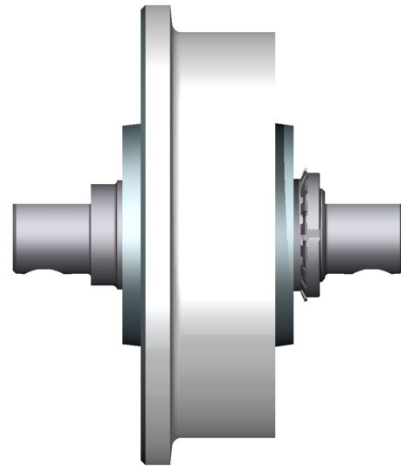

Example of designation

Wheel bearing nominal size 8

Wheel bearing 8 - BIS 5010

In case of inquiry or order please specify:

- special sizes / modifications
- material for the sheave (see site 4)
- lubrication via wheel or shaft
- lubricant

Remarks

- Wheel with inside bearing for radial and axial force compensation
- Flattened shaft for easy installation
- Lubrication optional left or right via wheel or shaft
- Lubrication optional with high temperatur lubricant

No wheel bearing is like the other...

Wheel bearings only rarely base on regular standards. Often used are special constructions of the running tread or different materials. According to individual operating conditions, the components are subject to totally different requirements which only can be met by detailed construction adjustments.

Here you get what you need!

Wheel bearings with roller bearings with single rim

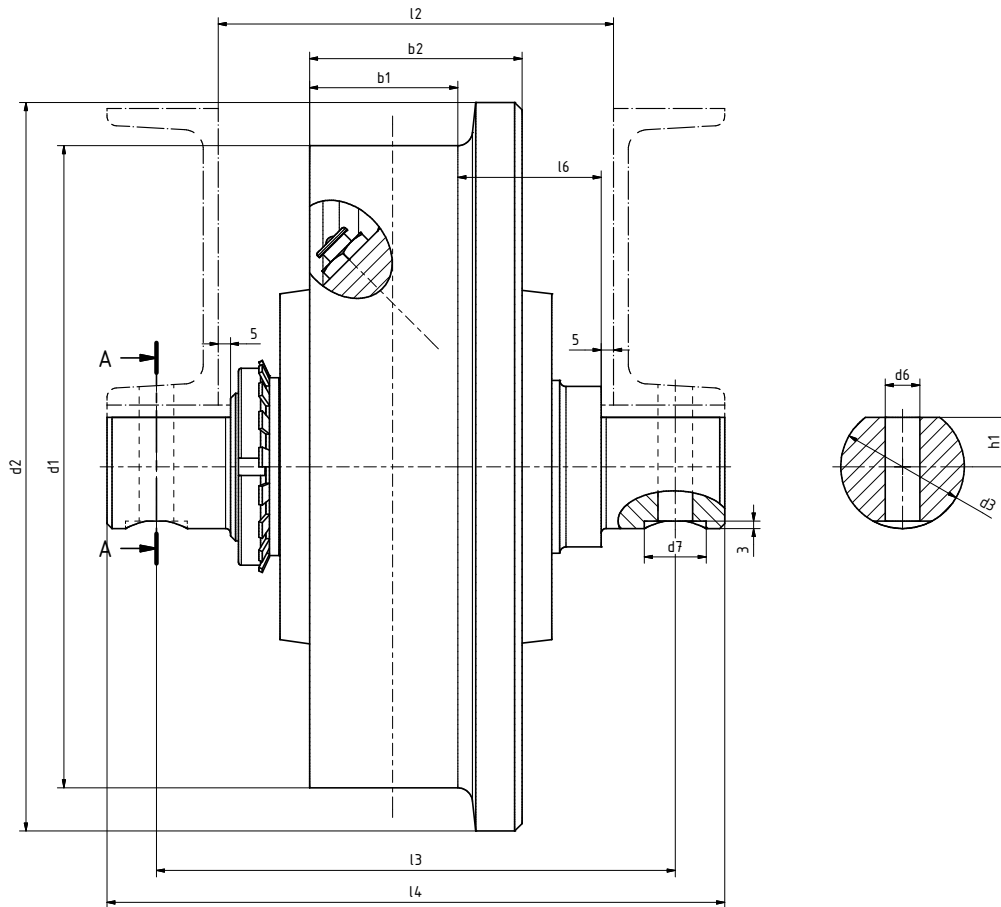

| nominal size | max. static wheel load kg | Wheel diameters and widths | | | | rail profile proposals | shaft dimensions | | | | installation dimensions | | | | | | | | | | | | |
|--------------|------------------------------|----------------------------|-----|----|----|------------------------|------------------|----|----|----|-------------------------|-----|-----|-----|-----|-----|----|-----|-----|-----|-----|-----|-----|
| | | d1 | d2 | b1 | b2 | | d3 | d6 | d7 | h1 | l2 | l3 | l4 | l6 | | | | | | | | | |
| 1 | 2.200 | 250 | 295 | 46 | 62 | S14 | 36 | 12 | 25 | 13 | 150 | 210 | 250 | 50 | | | | | | | | | |
| 2 | | 300 | 335 | | | | 41 | 15 | | | | | | | 275 | | | | | | | | |
| 3 | 3.000 | 260 | 295 | | | | 65 | | | | | | 45 | | | 15 | 15 | 165 | 225 | 275 | | | |
| 4 | | 300 | 335 | | | | | 50 | | | | | | | 70 | | | | | | 50 | 290 | |
| 5 | 4.000 | 300 | 335 | 55 | 75 | S24 | 55 | 19 | 30 | 15 | 170 | 240 | 300 | 52 | | | | | | | | | |
| 6 | | 350 | 385 | | | | | | | | | | | | 60 | 82 | 50 | 290 | | | | | |
| 7 | 5.200 | 300 | 335 | | | | | | | | | | 60 | | 82 | A55 | 70 | 24 | 40 | 22 | 200 | 270 | 330 |
| 8 | | 350 | 385 | | | | | | | | | | | | | | | | | | | | |
| 9 | 6.500 | 300 | 335 | 60 | 82 | A55 | 70 | 24 | 40 | 22 | 200 | 270 | | 330 | | | | | | | | | |
| 10 | | 350 | 385 | | | | | | | | | | | | | | | | | | | 70 | 92 |
| 11 | 7.500 | 350 | 385 | | | | | | | | | 60 | 82 | A55 | 70 | 24 | 40 | 22 | 200 | 270 | 330 | | |
| 12 | | 400 | 435 | | | | | | | | | | | | | | | | | | | 70 | 92 |
| 13 | 9.200 | 350 | 385 | 60 | 82 | A55 | 70 | 24 | 40 | 22 | 200 | | | | | | | | | 270 | 330 | | |
| 14 | | 400 | 435 | | | | | | | | | | | | | | | | | | | 70 | 92 |
| 15 | 10.800 | 350 | 385 | | | | | | | | | 60 | 82 | A55 | 70 | 24 | 40 | 22 | 200 | 270 | 330 | | |
| 16 | | 400 | 435 | | | | | | | | | | | | | | | | | | | 70 | 92 |
| 17 | 12.600 | 350 | 385 | 60 | 82 | A55 | 70 | 24 | 40 | 22 | 200 | | | | | | | | | 270 | 330 | | |
| 18 | | 400 | 435 | | | | | | | | | | | | | | | | | | | 70 | 92 |

Our material preselection ...

Choose the optimal material for your application.

Due to many years of experience, we are able to offer you an exclusive preselection of excellent materials. Using the following materials, you are always on the safe side. Next to technical issues, we also consider economic aspects to be able to offer you price and performance in the best relationship.

Wheels made of cast steel

| short name | heat treatment | tensile strength R_m in N/mm ² |
|----------------------|-----------------|--|
| GE300 (GS-60) | normalised (+N) | 520 bis 670 |
| GS-70 | normalised (+N) | > 690 |

Wheels made of forged steel

| short name | heat treatment | tensile strength R_m in N/mm ² |
|------------|-----------------|--|
| C45 | normalised (+N) | > 560 |
| C60 | normalised (+N) | > 650 |

Further components

Further components like covers and shafts are normally made of S355J2.

All other parts meet the regulations of the respective standard.

Do you need special designed components?

Please specify in your inquiry / order.

Further material information

On our website you can download data sheets of all above mentioned materials.

Visit us on:

www.boehmer-crane-wheels.com

General information

Technical design

The technical design of the wheel bearings needn't automatically correspond to standards. The construction can be adjusted in almost any parameter to fulfil the customer's demands. This corresponds to the geometric design, the materials used as well as different bearings.

All mentioned standards just serve as a basic orientation.

Materials

The materials mentioned and properties of this BIS collection are obtained from current valid DIN EN standards. Our material preselection is based on experience and does not serve as binding specification. According to your requirements, other materials can be provided.

Painting and conservation

If there is no specification concerning painting and conservation, our wheel bearings are executed to our standard. This comprises a surface painting with a one-component zinc phosphate primer in RAL 7031 (slate blue) and the conservation of all contact- and function surfaces with Tectyl 506 EH-40.

Customised paintings, as well as complete painting systems to supplier specifications are certainly possible.

Prices and delivery time

Almost every construction supplied by us is individually designed. Numerous executions make it impossible to give prices in advance. Please ask for price and delivery time. It will be our pleasure to help.



Your personal contact - competent and friendly

Inquiry

In order to be able to reply to your inquiry as soon as possible, it is important to provide us with all necessary information.

Please contact us for further information and support!

Sales

Export

Tel: +49 (0) 2302 / 961 - 141
Fax: +49 (0) 2302 / 961 - 222
Mail: info@kranlaufрад.de

Technology

Engineering

Tel: +49 (0) 2302 / 961 - 160
Fax: +49 (0) 2302 / 961 - 222
E-Mail: info@kranlaufрад.de

Our responsibility

Quality Management according to ISO 9001:2015



Böhmer Zerspanungstechnik GmbH & Co. KG • Annenstraße 79 • 58453 Witten • Germany
Tel +49 (0) 2302 961 - 0 • Fax +49 (0) 2302 961 222 • www.kranlaufрад.de • info@eisenwerkboehmer.de